



OPERATOR MANUAL
SCREWS FOR FIXING SANDWICH PANELS TO STEEL SUBSTRATE
M12S-SP TYPE
No. OM_M12S-SP_E19

Installation carried out in an appropriate way, using professional tools is extremely important for proper and safe use of building fasteners. Always follow all instructions listed in this operator manual.

General rules:

- The operator manual, apply only to original products of Baltic Fasteners Sp. z o.o. bearing the Manufacturer's logo, which allows for their identification;
- The use of screws shall be confirmed by a fixing plan made on the basis of complete building data;
- When carrying out the fixing plan, observe the mounting parameters and take into account the loads of the connections given in valid approval or technical evaluation issued for the product;
- When carrying out the fixing plan, comply with applicable laws and standards;
- The sandwich panel Manufacturer's recommendations must be taken into account;
- The number and type of screws must be in line with the information given in the fixing plan;
- Only tools that are equipped with clutch adjustment should be use;
- Modification of **M12S-SP** screws is not permitted. Cutting of screws that extend beyond the structure is forbidden due to the risk of losing their load capacity;
- Products may only be used for their intended purpose.

Product selection rules:

- **M12S-SP** screws are subject to **PZH** certificate and may be used in accordance with its provisions;
- **M12S-SP** screws are covered by class **A1** reaction to fire and can be used in this class;
- The corrosion protection of the screws should be suitably selected for the corrosive environment in which they will be used. **M12S-SP** screws are protected against corrosion by coating **SUPER PREMIUM** with **1000h** resistance in a salt spray test, which allows them to be used in corrosive environments **C4**. Washers **E19** delivered with screws are made of stainless steel, which allows them to be used in corrosive environments **C4**;
- The length of the screws should be appropriately selected depending on the thickness of all fixed elements:
 - thickness of the sandwich panel at the fixing point;
 - thickness of **MSW** saddle washers if used;
 - thickness of **MSD** stress diffusers, if used;
 - thickness of **PES** sealing tapes, if used (tape thickness should not be greater than 3mm);
 - thickness of other components, if used.

In addition, the thickness of the steel substrate should be taken into consideration when choosing the length of the screws;

- Screws can be used on steel substrates of grade not worse than **S280GD**;
- Screws can be used for steel substrates with a minimum thickness of **4mm**;
- Maximum steel drilling capacity for screws **12mm**. Maximum tool speed **1800rpm**;
- When choosing the length of the screws, the thickness of saddle washers **MSW = 4mm** or stress diffuser **MSD = 1.2mm** must be taken into account;
- No face positioning in one plane, on the inner lining of sandwich panel, cause panel offset from the support. The distance between the inner lining and the support should be taken into consideration when selecting the length of the screws. In addition, during installation, the distance must be filled with a special spacing washer so that the sandwich panels are always mounted perpendicular to the support;
- In order to select the appropriate length of the screws, the thickness of all fixed elements must be summed. Then add to that sum the thickness of the steel substrate and check in the Baltic Fasteners product catalog exact length of the **M12S-SP** screws that is suitable for fixing the obtained thickness. The sum of the thicknesses of all the elements including substrate must be within the range $h_{min} - h_{max}$ given in the catalog; Product catalog is available on the website www.balticfasteners.com;
- When fixing sandwich panel to closed steel profiles(pipes), keep in mind that the length of the screws must be adjusted to the internal dimension of the profile so that chosen screw can be easily tightened. The distance between the end of the screw and the opposite side of the profile must be at least **5mm** as shown on the picture below.

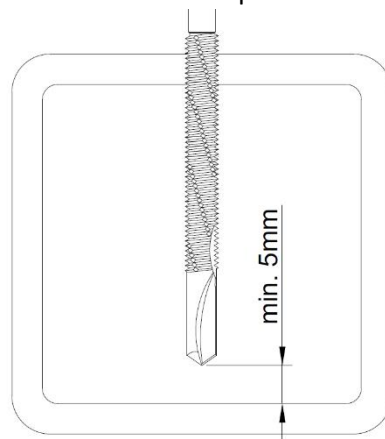

Installation process:

- Place the sandwich panel, following instruction provided by the panel Manufacturer. Use of the startup profiles is recommended. Use of **PES** insulating tapes at the contact surface between panel / support is recommended;
- When using **MSD** stress diffusers or **MSW** saddle washers, place them in the appropriate place on the sandwich panel before screwing in the screws. It is imperative to observe all the rules set out in the operator manual for those products;
- The sandwich panel (with **MSD** diffuser, **MSW** washer or without them) should be screwed to the substrate with the selected screws in accordance with the fixing plan.
 - a) Screws must always be mounted perpendicular to the substrate.
 - b) The EPDM should be properly tightened as shown on the picture below. Recommended tightening torque **5Nm**.

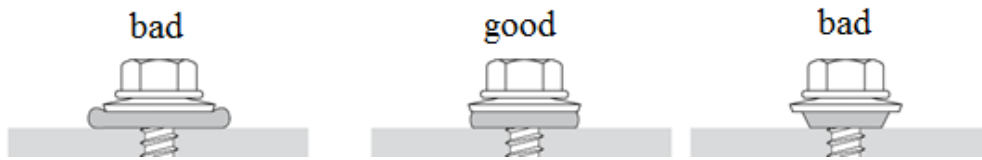

c) The distance from the fixing point to the edge of the steel profile must be minimum **10mm**.

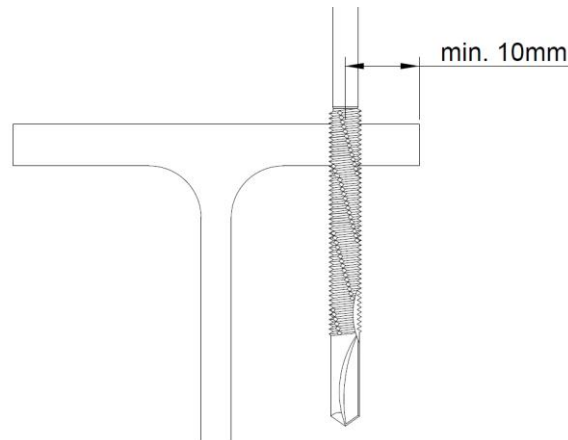

d) When mounting to hot-rolled I-beam profiles, mounting near the web is not recommended due to the increasing thickness of the flange in its direction.

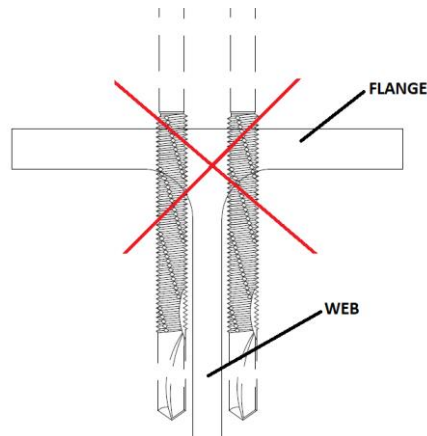

e) With properly selected screws, at least the whole drilling point and two full threads must be protruded outside of the structure (visual inspection is not possible when fixing to closed profiles).

f) Fixing parameters specified for the screw **M12S-SP** need to be retained.

g) Use dedicated nut-setters for a given screw line. For fixing screws coated with paint use spring nut-setters.

h) The sandwich panel should be fixed to each support at least with **2** screws to balance the system;

- In case of damage to the corrosion or paint coating on the screws, the defects must be further secured;
- When installing roofing sandwich panels, waves of the upper lining (overlap) should be connected longitudinally by using overlapping screws with washer, for example **M0 4,8x20**. The distance between screws should be **max. 250mm**;
- Once you have fixed the panel, proceed to assemble the next one by following the procedure given above.

Pictures 1-3 illustrate the fixing of **M12S-SP** screws to steel substrate with or without accessories.

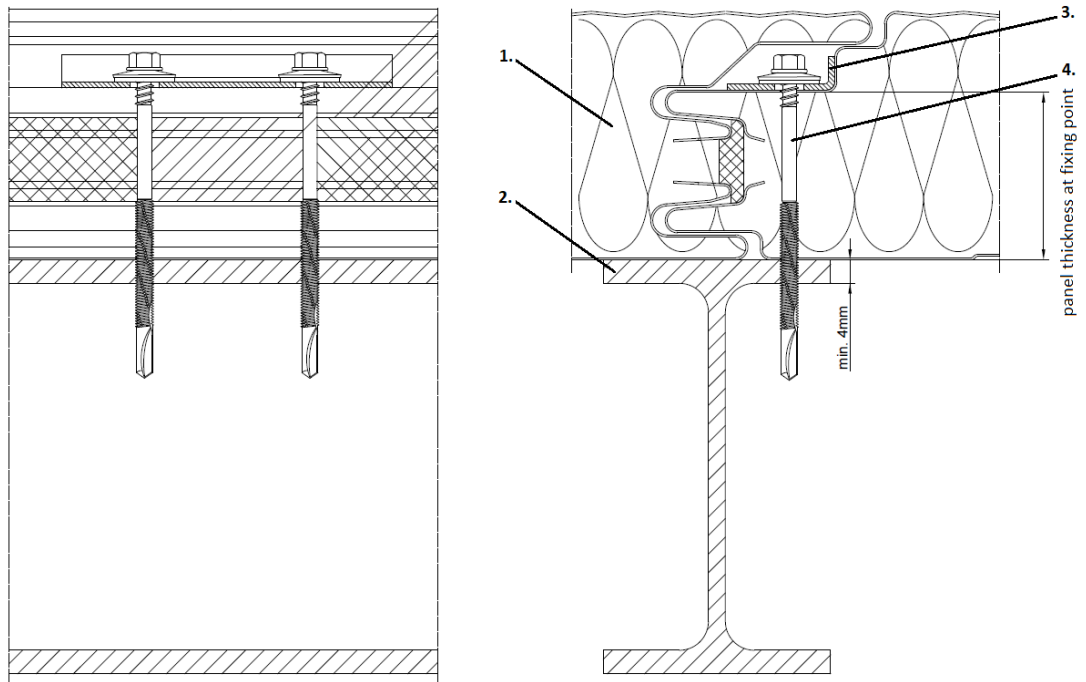

1. Sandwich panel
2. Steel profile
3. Stress diffuser MSD
4. Sandwich panel screw

Picture 1. Assembling of the M12S-SP with wall sandwich panel on steel substrate with use of MSD stress diffuser.

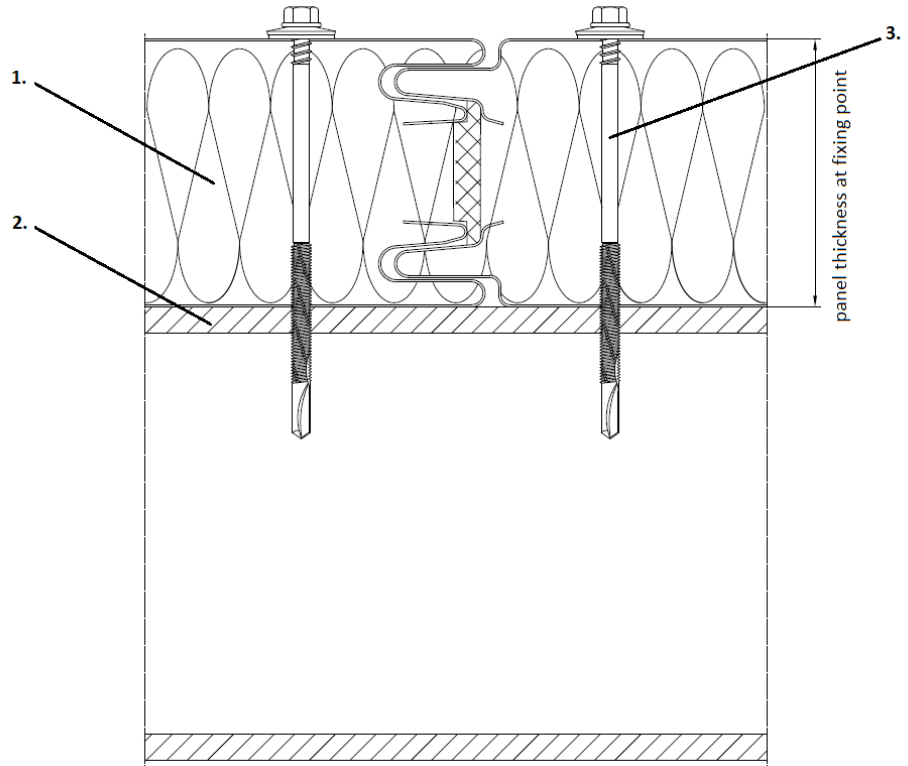

1. Sandwich panel
2. Steel profile
3. Sandwich panel screw

Picture 2. Assembling of the M12S-SP with wall sandwich panel (attachment visible) on steel substrate - cross section across the sandwich panel.

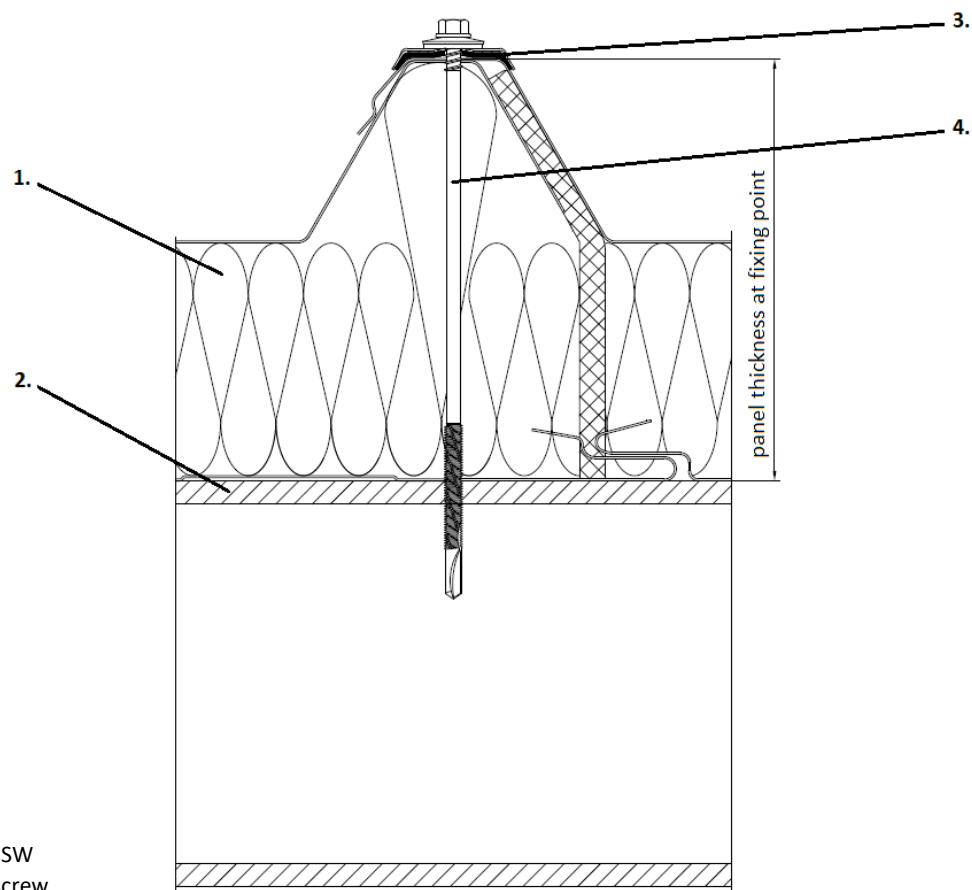

1. Sandwich panel
2. Steel profile
3. Saddle washer MSW
4. Sandwich panel screw

Picture 3. Assembling of the M12S-SP with roofing sandwich panel on steel substrate with use of MSW saddle washer - cross section across the sandwich panel.

Basic dimensions of screws M12S-SP type:

